

Bilco Sloped Wall Basement Door Installation Instructions



Better Living Basements™

The Bilco Company, P.O. Box 1203, New Haven, CT 06505
(203)934-6363 Fax (203) 933-8478
<http://www.bilco.com>

For a satisfactory installation, read the following Instructions before the job begins:

- Foundation Requirements: SECTION A, page 2
- Foundation Plates: SECTION B, page 2
- Door Assembly and Installation: SECTION C, page 4

Note: The Bilco Sloped Wall Basement Door must be installed square and level on a structurally sound foundation.

The Bilco Door is designed to operate with ease, keep your stairs dry and free of debris, and deliver many years of trouble free service when installed in accordance with these instructions. Some installations may require that you drill and cut metal. Be sure to use the proper tools, wear proper safety equipment and clothing, and secure any item to be drilled or cut to a stable work surface.

The names of the door parts referred to in the instructions appear below:

Minimum headroom requirements will vary according to each areaway. To determine headroom for your areaway, refer to the chart below and find the net clear opening for your door size. Measure from the lower end of your sidewall up to the dimension on the chart. Drop a plumb line from this point to the stairs. This is the minimum headroom of your areaway.

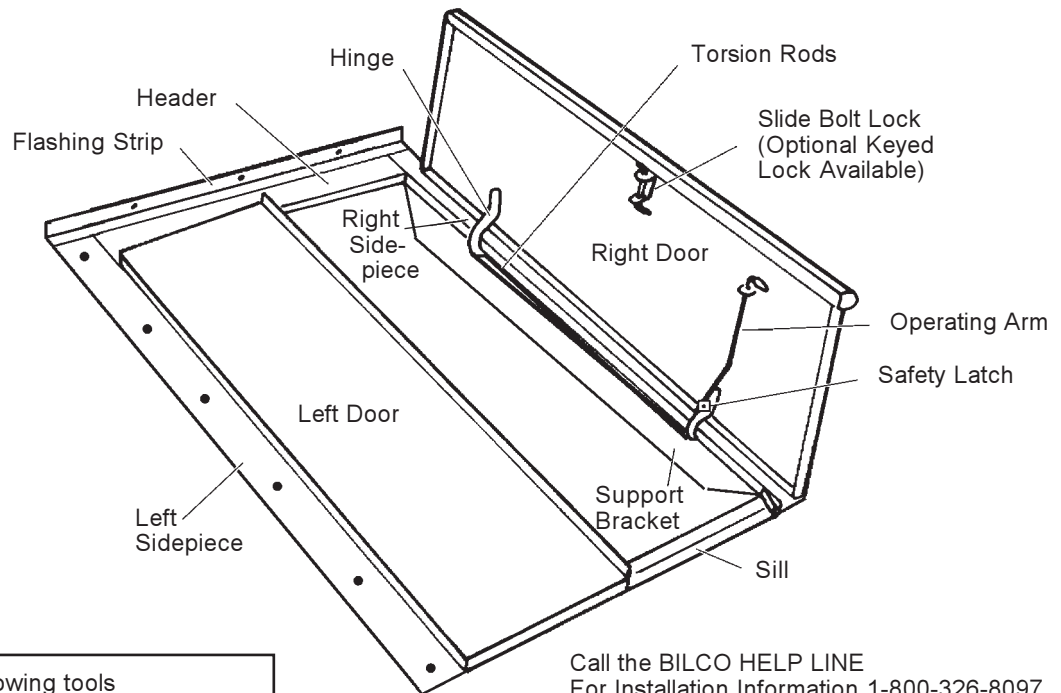

Door Size	Net Opening
SLW 3641	57"
SLW 4651	57"
SLW 4751	67"
SLW 5055	60"
SLW 5459	67"

Depending on the installation, the following tools and material may be required:

- | | |
|-------------------------|------------------------------------|
| Hammer and Nails | Pry Bar |
| Sledge Hammer | Level |
| Masonry Chisel | Tape Measure |
| Circular Saw | Abrasive Metal Cutting Blade |
| Jig Saw | Metal Cutting Jig Saw Blade |
| Electric Drill | 1/4" + 9/32" High Speed Drill Bits |
| 7/16", 9/16" Wrenches | 1/4" Carbide Masonry Drill Bit |
| Flat blade Screwdriver | Hack Saw |
| Work Gloves | Shovel and Trowel |
| Eye Protection | Mortar Tub |
| (1) Tube Silicone Caulk | Hearing Protection |

Call the BILCO HELP LINE
For Installation Information 1-800-326-8097
weekdays from 9 AM to 5 PM EST.

CAUTION

When the doors are open for access, the area should be personally guarded to prevent anyone from falling down the stairs. Doors should be closed and locked when not in use.

KEEP OFF DOORS TO AVOID INJURY

Surface may be slippery. In extreme conditions steel in the summer sun can become hot and cause injury. White enamel or other light color finish paint will reflect sunlight and reduce the temperature of the metal. **KEEP OFF DOORS**

SECTION A FOUNDATION REQUIREMENTS

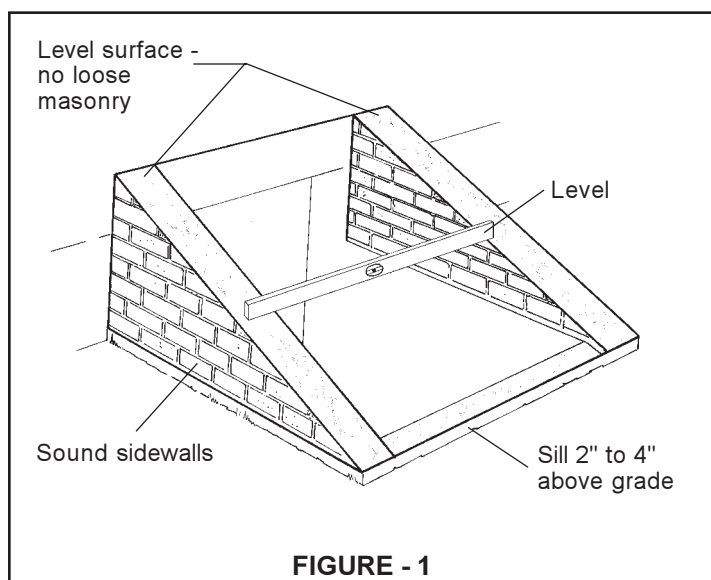

To operate properly, the Bilco Door must be square and firmly anchored to a sound foundation. Each sloped foundation sidewall must:

- be solid, with no loose or crumbling masonry
- have a uniformly flat and level surface on which to anchor the Bilco Door
- be uniformly level with the opposite sidewall

The sill must be 2" to 4" above grade.

If repairs are needed, they should be done before the Bilco Door is installed. See the following guidelines, HOW TO REPAIR MASONRY SIDEWALLS.

HOW TO REPAIR MASONRY SIDEWALLS

1) Mortar Joints Loose or Crumbling

Remove loose material and crumbling mortar to solid masonry, or a depth of one inch, whichever is greater. Clean all surfaces with water. Refill joints with pre-mixed, bagged mortar cement, following instructions on mortar bag. See your masonry supply dealer for complete information.

2) Sidewalls Need Reinforcing and Resurfacing

Apply fiberglass surface bonding cement to both sides of the walls to reinforce, resurface and waterproof them. Several brands are available from your mason supply dealer. Surface preparation and application methods are critical. Follow manufacturer's instructions for the brand you use.

3) Top Surface of Sidewalls is Rough, Not Level.

Prepare surface for new concrete cap by removing all loose material down to solid masonry, rough up surface and clean with water. Apply masonry bonding agent and pour new concrete cap using bagged, pre-mixed concrete mix. Check with your mason supply dealer for best bonding agent and concrete mix. Form a level surface on top of each sidewall and be sure both walls are level with each other. Pressure treated wood may be used instead of concrete. It must be level, caulked and firmly anchored to the foundation. You may wish to use Bilco Foundation Plates, available from your Bilco Dealer, to finish the top of the sidewalls. See SECTION B for information.

4) Single Course Brick Sidewalls

Brick sidewalls that are only one brick wide may not be strong enough to support the Bilco Door. They should be reinforced with another course of brick, or by a concrete wall poured against the brick wall and tied into it with wall ties.

SECTION B OPTIONAL FOUNDATION PLATES

Bilco foundation plates are available from your Bilco dealer. See size chart on page 3 for dimensions. Foundation plates are installed on top of areaway foundation sidewalls to:

- improve areaway appearance
- cover rough masonry and small holes, and span voids in brick and concrete block
- reduce the inside width of the areaway foundation
- for corner installations with one side supported by house

1) How to Cut Foundation Plates

Foundation plates must be cut to fit areaway. For best appearance, cut ends that go against house and scribe 1-3/4" side to fit flush against house. For safety, work gloves, eye and hearing protection and long sleeves are recommended. Do not cut near flammable materials. Firmly clamp plate to a solid surface. Cut with a circular saw and an abrasive metal cutting blade, a reciprocating saw or jig saw and a metal cutting blade with 18 to 24 teeth per inch, or use a hacksaw. Do not force blade through steel.

2) How to Install Foundation Plates

Foundation plates are 84" long. Select correct width for your foundation, determine overall length, and cut to fit (note: foundation plates are installed with 1-3/4" flange on outside of sidewall, see Figure - 2 below). If areaway is longer than 84", overlap two foundation plates. To do this, place a full length foundation plate at low end of each sidewall and cut a piece long enough to fill gap and overlap first plate by at least one inch, see Figure -2 below. Foundation plates must be level. If necessary, level top of sidewalls with mortar before installing foundation plates. Foundation plates must be firmly anchored to foundation with 1/4" lead or steel masonry anchors (not supplied). If door frame overlaps foundation by at least 2", the foundation plates and door frame can be anchored to the foundation at the same time, using the nail-in anchors in door hardware. Assemble door frame per SECTION C Step - 1. Place foundation plates on foundation and position door frame on top of foundation plates per Step - 2. Using predrilled holes in door sidepieces as a guide, drill 9/32" holes with a metal drill bit through foundation plates. Change to a 1/4" carbide tipped masonry bit and drill 2-1/4" deep holes into solid masonry. If foundation walls are concrete block or brick, drill holes in solid portions of the masonry. Follow Step 3 to anchor door to foundation. If door frame does not overlap foundation by at least 2", anchor foundation plates to areaway foundation using 1/4" nail-in anchors provided with the door hardware. Locate anchors at least 6" from the inside edge of the foundation plate, space 18" apart, and anchor door frame to the foundation plates with 1/4" round head bolts and nuts (purchased separately). It may be necessary to chisel pockets in foundation for bolts and nuts.

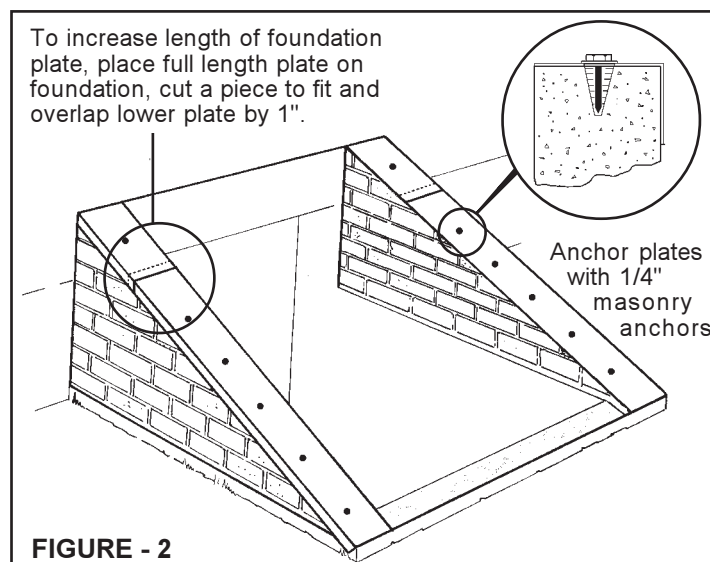

Foundation Plate Size Chart

Model	Width	Length	Height
FP5	5"	84"	1-3/4"
FP8	8"	84"	1-3/4"
FP11	11"	84"	1-3/4"
FP14	14"	84"	1-3/4"

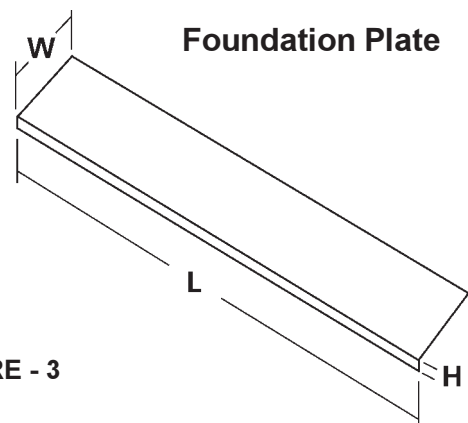

FIGURE - 3

3) How to Reduce Inside Width of Areaway

Select foundation plates that are wide enough to cover the top of the foundation and reduce the width of the areaway for proper fit of the Bilco Door. Figure - 4 shows an areaway with 8" sidewalls and 60" inside width. Figure - 5 shows two 11" foundation plates used to reduce the inside width to 54". If necessary, you can use a different width foundation plate on each sidewall for proper fit. Cut the foundation plates to the proper length, and drill 9/32" holes, at least 6" from the inside edge of the foundation plate, every 18". Change to a 1/4" carbide tipped masonry drill bit and use the holes in the foundation plates as a guide to drill 1/4" x 2-1/4" holes in the foundation. Anchor foundation plates to solid, level masonry with 1/4" nail-in anchors provided in the door hardware package. If the foundation plates overhang the foundation by more than 6", fasten pressure treated wood or angle iron to the inside of the masonry foundation so that it supports the entire length of foundation plate. Assemble the door frame per SECTION C, Step - 1. Position frame on firmly anchored foundation plates per Step 2. Verify that door frame is level and square. Using predrilled holes in door frame as a guide, drill 9/32" holes in the foundation plates using a metal drill bit. Apply bead of silicone caulking compound under door frame where it meets foundation plates and around each anchor hole. Anchor door frame to foundation plates using 1/4" x 1/2" bolts and 1/4" hex nuts (not supplied).

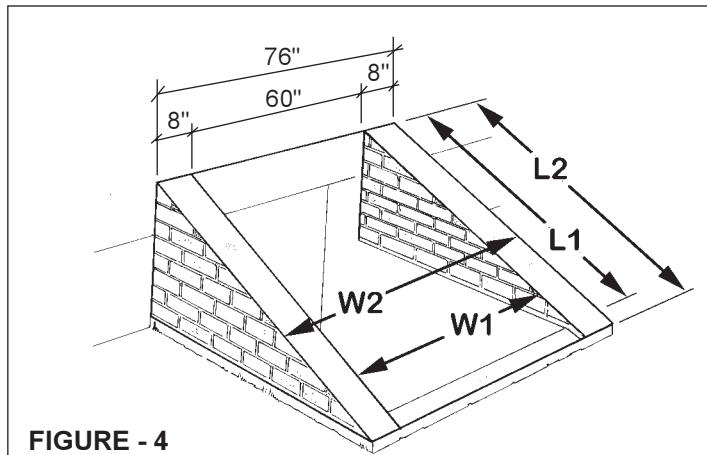

FIGURE - 4

4) How to Install When Areaway is in a Corner With One Side Supported by House

Select a foundation plate wide enough to allow the door leaf to open completely and safety latch to engage. Cut foundation plate to length, drill 9/32" holes every 18" in 1-3/4" flange, and place it against house with 1-3/4" flange facing up, per Figure - 6. Be sure that foundation plate is level with opposite areaway sidewall. Mark hole locations on house foundation. If necessary remove siding so that foundation plate can be anchored directly to house foundation or sheathing. Drill 1/4" x 1-1/2" deep holes in house foundation. Fasten foundation plate to house foundation through 1-3/4" up-turned flange. For masonry construction, use 1/4" x 1-1/2" masonry lags and shields (purchased separately). For wood construction, use wood screws. Caulk foundation plate where it meets house with silicone caulk (not supplied). Go to SECTION C for Door Assembly and Installation Instructions.

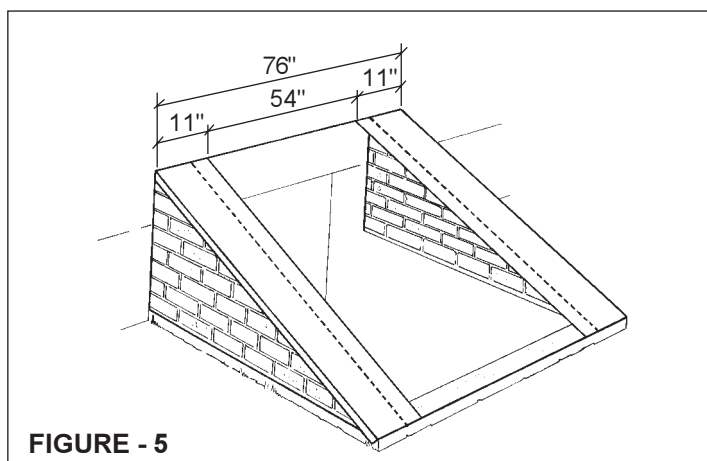

FIGURE - 5

PAINTING INSTRUCTIONS

The BILCO Basement Door must be painted immediately after installation. The BILCO Basement Door and optional extension panels are supplied with a uniform baked-on prime coating applied by a Flo-Coat Process. Immediately after installation, clean all interior and exterior steel surfaces thoroughly and apply a finish coat of alkyd metal enamel in white or other light color.

Optional foundation plates are galvanized steel but can be painted for aesthetic purposes. If painted, a metal primer must be used prior to applying the finished coat of paint.

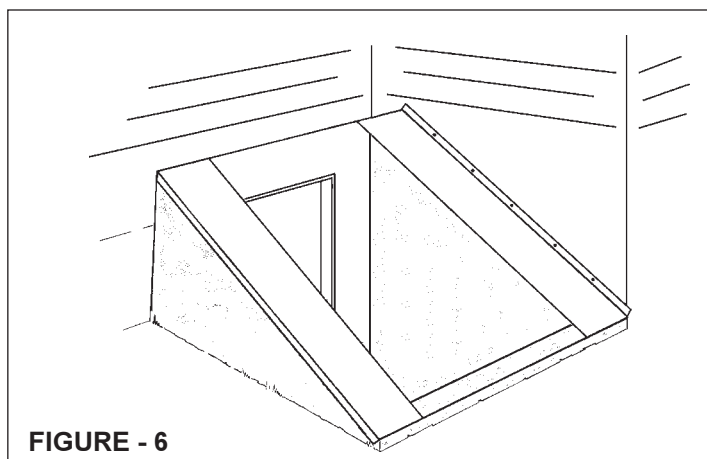

FIGURE - 6

SECTION C DOOR ASSEMBLY AND INSTALLATION

CAUTION: The BILCO Basement Door sheds water in all normal conditions only when installed and caulked in accordance with these instructions. If there are no rain gutters above, a diverter must be installed to prevent roof water from flowing directly onto the BILCO Door.

Sloped sidewalls must be structurally sound and level for proper operation of your new Bilco Door. Remove the old door and check sidewalls (see Figure - 1 on page 2). If no repairs are required, begin your installation with Step - 1.

STEP - 1 Assemble Door Frame

The Bilco SLW basement door consists of nine parts (see front cover for part names), four torsion rods with cams (Note: Model SLW3641 contains two torsion rods only), and the hardware package*. Begin assembly of frame by attaching support brackets to sidepieces with carriage bolts and locknuts per Figure 7. **Apply header caulking strips provided** to each header end plate per Figure - 8A. Attach header to sidepieces with four 1/4" round head bolts and nuts. (Note: to determine SLW left side from right side, position so that the two holes in the upturned flange of each side are at the bottom, see Figure - 8C). Header end plates must be under the sidepieces, with bolt heads facing out, per Figure - 8B. Tighten bolts until caulking squeezes out. Remove excess caulk and use it to fill inside joint, per Figure - 8B. Attach sill to sidepieces with four 1/4" flat head bolts. **Nuts must face inside**, per Figure - 8C. Hand tighten.

* Hardware

- (10) 5/16" x 3/4" carriage bolts and locknuts
- (6) 1/4" x 5/8" round head bolts and nuts
- (4) 1/4" x 1/2" flat head bolts and nuts
- (4) 5/16" x 1-1/4" hinge pins with cotter pins
- (15) 1/4" x 2" nail-in anchors
- (2) strips header caulking compound
- (4) rubber door bumpers
- (1) vial lubricant

STEP - 2 Position Door Frame on Foundation

Be sure masonry foundation is in good condition and level, clean and dry. Door sidepieces must overlap foundation sidewalls by at least 2" on each side. If overlap is less than 2", install Bilco Foundation Plates according to SECTION B before door frame is placed on foundation. Move assembled door frame into place on foundation. For proper door operation, **the frame must be level and square**. To square, see Figure - 9 and measure diagonals from top right inside corner to bottom left inside corner of frame and from top left inside corner to bottom right inside corner. Move lower end of frame to left or right until diagonal measurements are equal. Adjust sill by pivoting until level and tighten bolts. To adjust sill on extremely high sidewalls, it may be necessary to remove the upper sill bolts.

STEP - 3 Anchor Door Frame To Foundation

The door frame must be securely anchored to a sound masonry foundation, or to foundation plates that are firmly anchored to the foundation. **No part of the Bilco Door should be covered with concrete.** Apply bead of silicone caulking compound (not supplied) to clean, dry masonry foundation (or optional foundation plates) underneath door frame, per Figure - 10. Verify that door frame is level and square. Using pre drilled holes in sidepieces and sill as a guide, drill holes into the foundation 2-1/4" deep using a 1/4" carbide tipped masonry bit. Apply silicone caulk around each anchor hole and insert nail-in anchors, making sure anchor heads contact door frame and are embedded in caulk. Hammer nailpins down until flush.

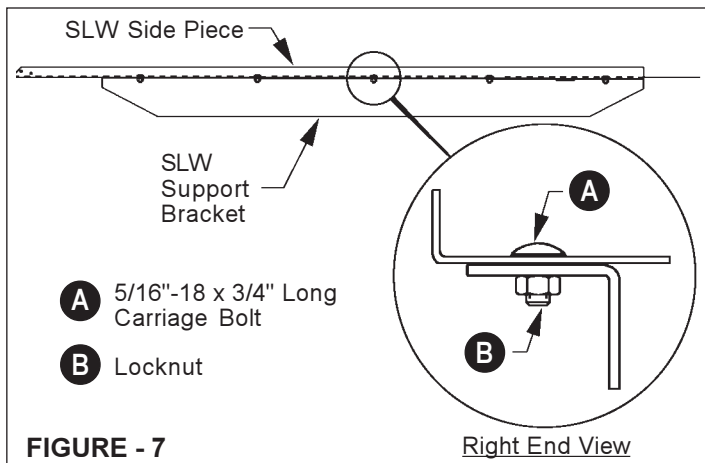

FIGURE - 7

Right End View

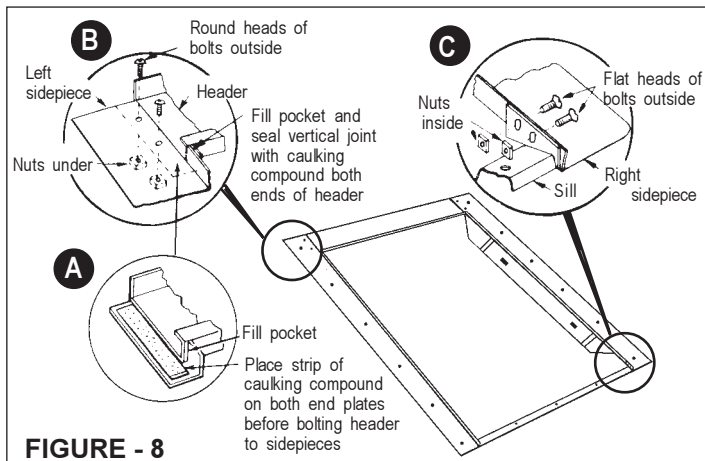

FIGURE - 8

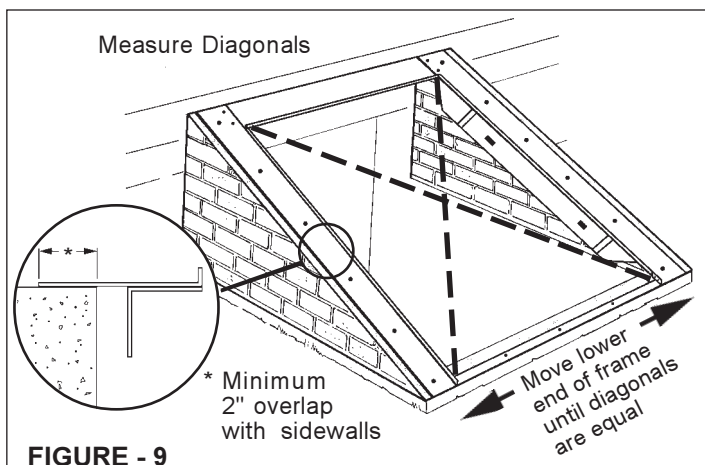

FIGURE - 9

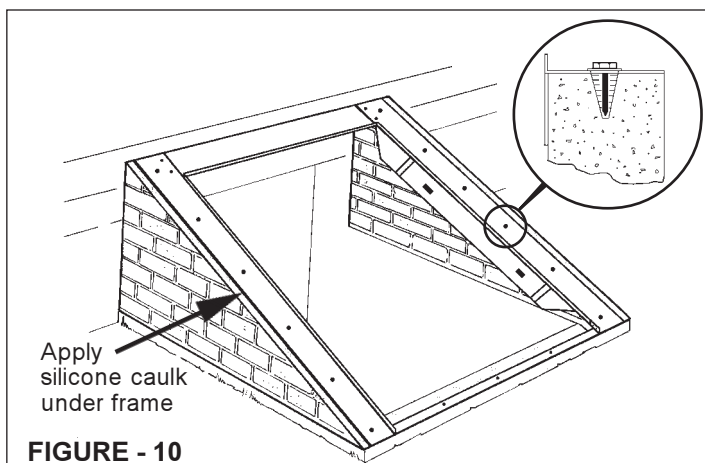

FIGURE - 10

STEP - 4 Install Flashing Strip

Flashing strip must **overlap the header by at least 3/4"**.^{*} To install the flashing strip, remove the two top bolts from the door header. Position flashing strip on door with upturned flange against house, per Figure - 11A. Fit upturned flange under siding, per Figure - 11B, and apply a bead of silicone caulk under perimeter of flashing strip where it overlaps door header. Nail flashing strip to sheathing or anchor to masonry with 1/4" concrete anchors purchased separately. Use holes in flashing strip as a guide and drill two 9/32" holes through middle of door header, apply silicone caulk around each hole and fasten flashing strip to door header with 1/4" round head bolts and nuts. Drill one 9/32" hole at each end of flashing strip through door sidepieces, change to a masonry drill bit and drill 1/4" x 2-1/4" deep holes into the masonry. Apply caulk around holes, insert nail-in anchors provided and hammer nailpins down until flush with door frame.

^{*}If space between door header and house is greater than flashing strip, or overlap is less than 3/4", extension panels are available from your BILCO dealer in 6" and 12" widths.

STEP - 5 Install Doors

Install right door per Figure - 12A by holding it vertically over right side piece so that hinges fit into hinge brackets on sidepiece. Line up holes in hinges with hinge pivot holes in brackets and insert 5/16" x 1-1/4" hinge pins and cotter pins. Install left door in same manner.

Caution: Before closing doors, disengage safety latch on lower hinge of each door.

STEP - 6 Install Torsion Rods

There are two rods marked #1 and two marked #2. Markings can be found on the plastic component on each rod. Each door requires one #1 and one #2 torsion rod. (Note: Model SLW 3641 uses only two rods)

Before installing the rods, apply lubricant to plastic components per sketch included with packet containing lubricant vial.

To install torsion rods on all models except SLW3641:

Left door: Open left door so safety latch engages. Refer to Figure - 12B and install rod #1 first, then install rod #2 so that it passes under rod #1. Insert "U" shaped end of rod #1 through hole in upper hinge bracket of left sidepiece, as shown in the diagram. Insert "L" shaped end of rod UP into the lower retainer. Insert "U" shaped end of rod #2 through hole in lower hinge bracket of left sidepiece, as shown in diagram. Insert the "L" shaped end of the rod DOWN into the upper retainer. Rod #2 should pass under rod #1.

Right door: Open right door so safety latch engages. Refer to Figure - 12C and install rod #1 first, then install rod #2 so that it passes under rod #1. Insert "U" shaped end of rod #1 through hole in lower hinge bracket of right sidepiece, as shown in the diagram. Insert "L" shaped end of rod UP into the upper retainer. Insert "U" shaped end of rod #2, through hole in upper hinge bracket of right sidepiece, as shown in diagram. Insert the "L" shaped end of the rod DOWN into the lower retainer. Rod #2 should pass under rod #1.

To install torsion rods on model SLW3641 doors:

Open door so safety latch engages. Refer to Figure - 12B (for left door) or Figure 12-C (for right door) and insert "U" shaped end of rod through hole in lower (for left door) or upper (for right door) hinge bracket of sidepiece, as shown in the diagram. Insert the "L" shaped end of the rod DOWN into the upper (for left door) or lower (for right door) retainer.

Optional Keyed Lock Available

A short time to install, Contact Bilco or your local Basement Door Dealer for more information

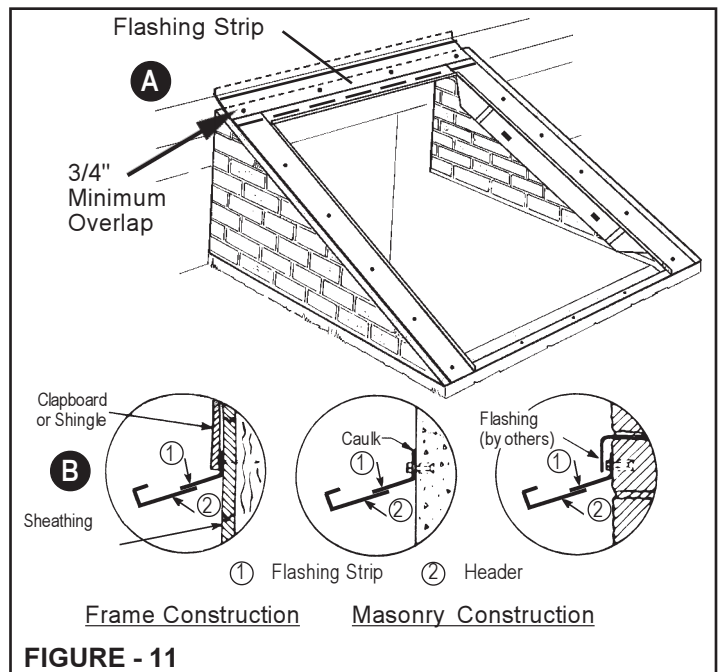
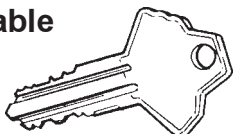

FIGURE - 11

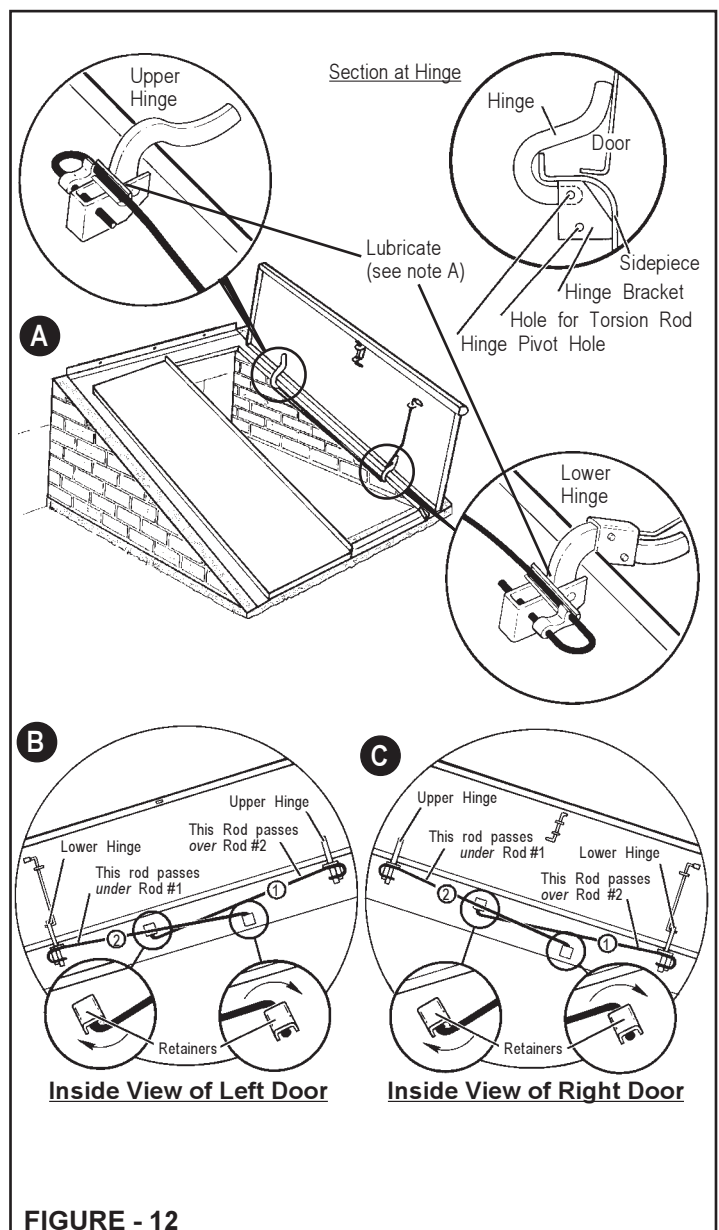

FIGURE - 12

How to correct installation errors or repair minor damage

Door not shedding water. If your Bilco basement door does not shed water, look for and correct these installation errors.

1. Header end plates not caulked. Loosen header bolts and pry plate down from below with a screwdriver. Push caulking in on top of header end plate and retighten bolts. Fill pockets provided by protrusion of metal at each corner (see Figure - 8A & 8B , page 4).
2. Doors do not fully close. Stand on steps and slowly close each door to see if the bottom flange of one or both is binding on the concrete. Chip away or rub down excess concrete with mason's stone so flange is not obstructed. Refer to instructions at right for adjustments if required.
3. Sill not high enough. The masonry under the Bilco basement door should be 4" higher than the surrounding grade and concrete should be level so water cannot accumulate in front of the sill.
4. Water seeping between steel and masonry. The unit should be caulked all around the exterior where the steel and masonry meet, as well as where the unit joins the building wall. If sidepieces have been buried in concrete, the unit should be removed and sidewalls recapped so assembly rests on top.
5. Blocked header channel. Make certain channel is clear. Any blockage in this channel will cause water to overflow the header.

NOTE: To check your door, set garden hose on medium spray and direct it upward so water falls on the door to simulate rain.

Doors Out of Alignment. This is caused by failure to align the doors and square the frame as instructed. With doors closed, sight across bottom. Remove door that is higher than the other.

Hold vertically with **top edge** on the ground as shown. Strike each hinge three or four solid blows with a hammer. This bends hinges in the direction of top of door, thus lowering it to line up with other door (See Photo #1 below). If additional adjustment is necessary, remove lower door, place lower end on ground and strike each hinge with a hammer. This bends the hinges in the direction of the bottom of the door, thus raising it to line up with other door.

Doors Not Seated Properly. If doors do not seat themselves properly or bounce slightly when in closed position, and bottom flanges of doors are not obstructed by concrete in front of sill, apply lubricant such as WD-40 to hinges and cams, then refer to Step - 2 on page 4 and: (a) check frame for level and square, and (b) from below with door open three-quarters of the way, insert a screwdriver along side of hinge and pull door down on it to a point where you feel pressure of the screw driver relieving binding condition (See Photo #2 below).

Hinge Damaged. A hinge can be bent downward by mishandling during shipment or by someone trying to force the door closed without releasing the hold-open safety latch, and as a result the door does not fit properly on the frame. Such damage to a hinge can be identified by a bump on the top of the door. To correct, remove the door from the frame, place it on the ground with the hinge side up and step downward on the hinge to bend the pivot point back to its correct location. The other hinge on that door, which has not been damaged, can be used as a guide in bending the hinge back to the proper place (See Photo #3 below).

Door Warped or Bent. Place the end of the door on a block or bottom step of a nearby stairway, and step down on it with your foot. The door can be bent back to the original shape very easily this way, but when it is installed on the frame and supported all around it is extremely strong and will not bend during everyday use (See Photo #4 below).

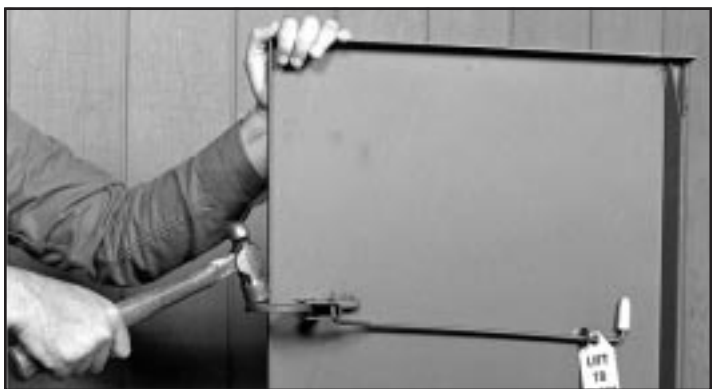

Photo - 1



Photo - 2



Photo - 3



Photo - 4